

AXOR®

hansgrohe

DE	Gebrauchsanleitung / Montageanleitung	2
FR	Mode d'emploi / Instructions de montage	2
EN	Instructions for use / assembly instructions	2
IT	Istruzioni per l'uso / Istruzioni per Installazione	2
ES	Modo de empleo / Instrucciones de montaje	3
DK	Brugsanvisning / Monteringsvejledning	3
NL	Gebruiksaanwijzing / Handleiding	3
PT	Instruções para uso / Manual de Instalação	3
PL	Instrukcja obsługi / Instrukcja montażu	4
SK	Návod na použitie / Montážny návod	4
CS	Návod k použití / Montážní návod	4
ZH	用户手册 / 组装说明	4
RU	Руководство пользователя / Инструкция по монтажу	5
FI	Käyttöohje / Asennusohje	5
HU	Használati útmutató / Szerelési útmutató	5
SV	Bruksanvisning / Monteringsanvisning	5
LT	Vartotojo instrukcija / Montavimo instrukcijos	6
TR	Kullanım kılavuzu / Montaj kılavuzu	6
HR	Upute za uporabu / Uputstva za instalaciju	6
RO	Manual de utilizare / Instrucțiuni de montare	6
EL	Οδηγίες χρήσης / Οδηγία συναρμολόγησης	7
ET	Kasutusjuhend / Paigaldusjuhend	7
LV	Lietošanas pamācība / Montāžas instrukcija	7
SL	Navodilo za uporabo / Navodila za montažo	7
SR	Uputstvo za upotrebu / Uputstvo za montažu	8
BG	Инструкция за употреба / Ръководство за монтаж	8
NO	Bruksanvisning / Montasjeveiledning	8
SQ	Udhëzuesi i përdorimit / Udhëzime rreth montimit	8
AR	دليل الاستخدام / تعليمات التجميع	9

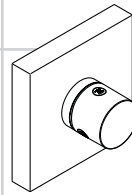

Starck
10932000

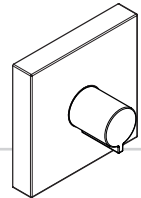

Starck
10972000
10972140

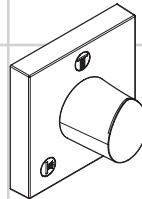

**Starck
Organic**
12731000

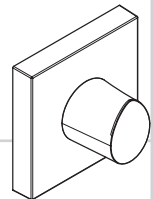

**Starck
Organic**
12771000

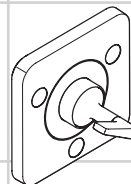

Citterio E
36772000

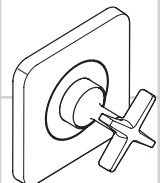

Citterio E
36771000



Sicherheitshinweise

- Bei der Montage müssen zur Vermeidung von Quetsch- und Schnittverletzungen Handschuhe getragen werden.

Montagehinweise

- Vor der Montage muss das Produkt auf Transportschäden untersucht werden. Nach dem Einbau werden keine Transport- oder Oberflächenschäden anerkannt.
- Die in den Ländern jeweils gültigen Installationsrichtlinien sind einzuhalten.



Kein essigsäurehaltiges Silikon verwenden!



Maße (siehe Seite 16)



Serviceteile (siehe Seite 17)



Prüfzeichen (siehe Seite 20)

Montage siehe Seite 10

Consignes de sécurité

- Lors du montage, porter des gants de protection pour éviter toute blessure par écrasement ou coupure.

Instructions pour le montage

- Avant son montage, s'assurer que le produit n'a subi aucun dommage pendant le transport. Après le montage, tout dommage de transport ou de surface ne pourra pas être reconnu.
- Les directives d'installation en vigueur dans le pays concerné doivent être respectées.



Ne pas utiliser de silicone contenant de l'acide acétique!



Dimensions (voir pages 16)



Pièces détachées (voir pages 17)



Classification acoustique et débit (voir pages 20)

Montage voir pages 10



Safety Notes

- Gloves should be worn during installation to prevent crushing and cutting injuries.

Installation Instructions

- Prior to installation, inspect the product for transport damages. After it has been installed, no transport or surface damage will be honoured.
- The plumbing codes applicable in the respective countries must be observed.



Do not use silicone containing acetic acid!



Dimensions (see page 16)



Spare parts (see page 17)



Test certificate (see page 20)

Assembly see page 10

Indicazioni sulla sicurezza

- Durante il montaggio, per evitare ferite da schiacciamento e da taglio bisogna indossare guanti protettivi.

Istruzioni per il montaggio

- Prima del montaggio è necessario controllare che non ci siano stati danni durante il trasporto. Una volta eseguito il montaggio, non verranno riconosciuti eventuali danni di trasporto o delle superfici.
- Vanno rispettate le direttive di installazione nazionali vigenti nel rispettivo paese.



Non utilizzare silicone contenente acido acetico!



Ingombri (vedi pagg. 16)



Parti di ricambio (vedi pagg. 17)



Segno di verifica (vedi pagg. 20)

Montaggio vedi pagg. 10



**! Indicaciones de seguridad**

- △ Durante el montaje deben utilizarse guantes para evitar heridas por aplastamiento o corte.

Indicaciones para el montaje

- Antes del montaje se debe examinarse el producto contra daños de transporte. Después de la instalación so se reconoce ningún daño de transporte o de superficie.
- Es obligatorio el cumplimiento de las directrices de instalación vigentes en el país respectivo.



No utilizar silicona que contiene ácido acético!



Dimensiones (ver página 16)



Repuestos (ver página 17)



Marca de verificación (ver página 20)

Montaje ver página 10

**! Veiligheidsinstructies**

- △ Bij de montage moeten ter voorkoming van knel- en snijwonden handschoenen worden gedragen.

Montage-instructies

- Vóór de montage moet het product gecontroleerd worden op transportschade. Na de inbouw wordt geen transport- of oppervlakteschade meer aanvaard.
- De in de overeenkomstige landen geldende installatie-richtlijnen moeten nageleefd worden.



Gebruik geen zuurhoudende siliconen!



Maten (zie blz. 16)



Service onderdelen (zie blz. 17)



Keurmerk (zie blz. 20)

Montage zie blz. 10

**! Sikkerhedsanvisninger**

- △ Ved monteringen skal der bruges handsker for at undgå kvæstelser og snitsår.

Monteringsanvisninger

- Før monteringen skal produktet kontrolleres for transportskader. Efter monteringen godkendes transportskader eller skader på overfladen ikke længere.
- Installationsbestemmelserne, der gælder i det enkelte land, skal overholdes.



Der må ikke benyttes eddikesyreholdig silikone!



Målene (se s. 16)



Reserve dele (se s. 17)



Godkendelse (se s. 20)

Montering se s. 10

**! Avisos de segurança**

- △ Durante a montagem devem ser utilizadas luvas de protecção, de modo a evitar ferimentos resultantes de entalamentos e de cortes.

Avisos de montagem

- Antes da montagem deve-se controlar o produto relativamente a danos de transporte. Após a montagem não são aceites quaisquer danos de transporte ou de superfície.
- A prescrições de instalação válidas nos respetivos países devem ser respeitadas.



Não utilizar silicone que contenha ácido acético!



Medidas (ver página 16)



Peças de substituição (ver página 17)



Marca de controlo (ver página 20)

Montagem ver página 10

**⚠ Wskazówki bezpieczeństwa**

- ⚠ Aby uniknąć zranień, takich jak zgniecenia czy przecięcia, podczas montażu należy nosić rękawice.

Wskazówki montażowe

- Przed montażem należy skontrolować produkt pod kątem szkód transportowych. Po montażu nie widać żadnych szkód transportowych ani szkód na powierzchni.
- Należy przestrzegać wytycznych instalacyjnych obowiązujących w danym kraju.

Nie stosować silikonów zawierających kwas octowy!

Wymiary (patrz strona 16)

Części serwisowe (patrz strona 17)

Znak jakości (patrz strona 20)

Montaż patrz strona 10

⚠ Bezpečnostní pokyny

- ⚠ Pro zabránění řezným zraněním a pohmožděním je nutné při montáži nosit rukavice.

Pokyny k montáži

- Před montáží je třeba produkt zkontrolovat, zda nebyl při transportu poškozen. Po zabudování nebudou uznány žádné škody způsobené transportem nebo poškození povrchu.
- Je třeba dodržovat montážní pravidla platné v dané zemi.

Nepoužívat silikon s obsahem kyseliny octové!

Rozměry (viz strana 16)

Servisní díly (viz strana 17)

Zkušební značka (viz strana 20)

Montáž viz strana 10

**⚠ Bezpečnostné pokyny**

- ⚠ Pri montáži musíte nosiť rukavice, aby ste predišli pomliaždeninám a rezným poraneniam.

Pokyny pre montáž

- Pred montážou musíte produkt skontrolovať, či nebol počas transportu poškodený. Po zabudovaní nebudú uznané žiadne škody spôsobené transportom alebo poškodenia povrchu.
- Je potrebné dodržiavať smernice o inštalácii, ktoré sú práve teraz platné v krajinách.

Nepoužívať silikón s obsahom kyseliny octovej!

Rozmery (viď strana 16)

Servisné diely (viď strana 17)

Osvedčenie o skúške (viď strana 20)

Montáž viď strana 10

⚠ 安全技巧

- ⚠ 装配时为避免挤压和切割受伤，必须戴上手套。

安装提示

- 安装前必须检查产品是否受到运输损害。安装后将不认可运输损害或表面损伤。
- 请遵守当地国家现行的安装规定。

请勿使用含有乙酸的硅！

大小 (参见第页 16)

备用零件 (参见第页 17)

检验标记 (参见第页 20)

安装 参见第页 10



Указания по технике безопасности

- Во время монтажа следует надеть перчатки во избежание прищемления и порезов.

Указания по монтажу

- Перед монтажом следует проверить изделие на предмет повреждений при перевозке. После монтажа претензии о возмещении ущерба за повреждения при перевозке или повреждения поверхностей не принимаются.
- Необходимо соблюдать требования по монтажу, действующие в соответствующих странах.

Не применяйте силикон, содержащий уксусную кислоту.

Размеры (см. стр. 16)

Комплект (см. стр. 17)

Знак технического контроля
(см. стр. 20)

Монтаж см. стр. 10

Biztonsági utasítások

- A szerelésnél a zúzódások és vágási sérülések elkerülése érdekében kesztyűt kell viselni.

Szerelési utasítások

- A szerelés előtt ellenőrizni kell, hogy a terméknek nincs-e szállítási sérülése. Beépítés után a szállítási- vagy felületi sérüléseket nem ismerik el.
- Az egyes országokban érvényes installációs irányelveket be kell tartani.

Ne használjon ecetsavtartalmú szilikont!

Méretet (lásd a oldalon 16)

Tartozékok (lásd a oldalon 17)

Vizsgajel (lásd a oldalon 20)

Szerelés lásd a oldalon 10



Turvallisuusohjeet

- Asennuksessa on käytettävä käsineitä puristumien ja viiltojen aiheuttamien tapaturmien estämiseksi.

Asennusohjeet

- Ennen asennusta on tarkastettava tuotteen mahdolliset kuljetusvahingot. Asennuksen jälkeen kuljetus- ja pintavaurioita ei hyväksytä.
- Jokaisessa maassa on noudatettava siellä päteviä asennusohjeita.

Älä käytä etikkahappopitoista silikonia!

Mitat (katso sivu 16)

Varaosat (katso sivu 17)

Koetusmerkki (katso sivu 20)

Asennus katso sivu 10

Säkerhetsanvisningar

- Handskar ska bäras under monteringsarbetet så att man kan undvika kläm- och skärskadorgen werden.

Monteringsanvisningar

- Det måste undersökas om produkten har transportskador innan den monteras. Efter monteringen accepteras inga transport- eller ytskiktsskador.
- De installationsriktlinjer som gäller i länderna ska följas.

Använd inte silikon som innehåller ättiksyra!

Måtten (se sidan 16)

Reservdelar (se sidan 17)

Testsigill (se sidan 20)

Montering se sidan 10



⚠ Saugumo technikos nurodymai

- ⚠ Apsaugai nuo užspaudimo ir įsijovimo montavimo metu mūvėkite pirštines.

Montavimo instrukcija

- Prieš montuojant būtina patikrinti, ar gaminy nebūvo pažeistas transportavimo metu. Sumontavus pretenzijos dėl transportavimo ir paviršiaus pažeidimų nepriimamos.
- Laikykitės atitinkamoje šalyje galiojančių direktyvų dėl įrengimo.



Nenaudokite silikono, kurio sudėtyje yra acto rūgšties!

Išmatavimai (žr. psl. 16)



Atsarginės dalys (žr. psl. 17)

Bandymo pažyma (žr. psl. 20)



Montavimas žr. psl. 10



⚠ Sigurnosne upute

- ⚠ Prilikom montaže se radi sprječavanja prignječenja i posjekotina moraju nositi rukavice.

Upute za montažu

- Prije montaže mora se provjeriti je li proizvod oštećen prilikom transporta. Nakon ugradnje se ne priznaju nikakve reklamacije koje se odnose na površinska i transportna oštećenja.
- Obvezno se moraju uvažiti propisi o instalacijama koji vrijede u dotičnoj zemlji.



Nemojte koristiti silikon koji sadrži octenu kiselinu!

Mjere (pogledaj stranicu 16)



Rezervni djelovi (pogledaj stranicu 17)

Oznaka testiranja (pogledaj stranicu 20)



Sastavljanje pogledaj stranicu 10



⚠ Güvenlik uyarıları

- ⚠ Montaj esnasında ezilme ve kesilme gibi yaralanmaları önlemek için eldiven kullanılmalıdır.

Montaj açıklamaları

- Montaj işleminden önce ürün nakliye hasarları yönünden kontrol edilmelidir. Montaj işleminden sonra nakliye veya yüzey hasarları için sorumluluk üstlenilmemektedir.
- Ülkelerde geçerli kurulum yönetmeliklerine riayet edilmelidir.



Asetik asit içeren silikon kullanmayın!

Ölçüleri (bakınız sayfa 16)



Yedek Parçalar (bakınız sayfa 17)

Kontrol işareti (bakınız sayfa 20)



Montajı bakınız sayfa 10



⚠ Instrucțiuni de siguranță

- ⚠ La montare utilizați mănuși pentru evitarea contuziunilor și tăierii mâinilor.

Instrucțiuni de montare

- Înainte de instalare verificați, dacă produsul prezintă deteriorări de transport. După instalare garanția nu acoperă deteriorările de transport și cele de suprafață.
- Respectați reglementările referitoare la instalare valabile în țara respectivă.



Nu utilizați silicon cu conținut de acid acetic!

Dimensiuni (vezi pag. 16)



Piese de schimb (vezi pag. 17)

Certificat de testare (vezi pag. 20)



Montare vezi pag. 10

**⚠ Υποδειξεις ασφαλειας**

- ⚠ Για να αποφευχete τραυματισμους κατὰ τη συναρμολογηση πρèπει να φορατε γαντια.

Οδηγιες συναρμολογησης

- Πριν τη συναρμολογηση πρèπει να εξεταστει το προιον για ζημιες μεταφορας. Μετα την εγκατασταση δεν αναγνωριζονται ζημιες απο τη μεταφορα η επιφανειακες ζημιες.
- Θα πρèπει να τηρουνται οι οδηγιες εγκαταστασης που ισχυουν σε καθε κρατος.



Μην χρησιμοποιεите σιλικονη που περιεχει οξικο οξυ!



Διαστασεις (βλ. Σελιδα 16)



Ανταλλακτικα (βλ. Σελιδα 17)



Σημα ελεγχου (βλ. Σελιδα 20)

Συναρμολογηση βλ. Σελιδα 10

**⚠ Varnostna opozorila**

- ⚠ Pri montaži je treba nositi rokavice, da se preprečijo poškodbe zaradi zmečkanja ali urezov.

Navodila za montažo

- Pred montažo je treba izdelke preveriti glede morebitnih transportnih poškodb. Po vgradnji transportne ali površinske poškodbe ne bodo več priznane.
- Upoštevati je treba pravilnike o inštalacijah, ki veljajo v posamezni državi.



Ne smete uporabiti silikona, ki vsebuje ocatno kislino!



Mere (glejte stran 16)



Rezervni deli (glejte stran 17)



Preskusni znak (glejte stran 20)

Montaža glejte stran 10

Estonia**Latvian****⚠ Ohutusjuhised**

- ⚠ Kandke paigaldamisel muljumis- ja löikevigastuste vältimiseks kindaid.

Paigaldamisjuhised

- Enne paigaldamist tuleb toodet kontrollida transpordikahjustuste osas Pärast paigaldamist ei tunnustata enam transpordi- või pinnakahjustuste kaebuseid.
- Vastavas riigis kehtivaid paigalduseeskirju tuleb järgida.



Ärge kasutage äädikahapet sisaldavat silikooni!



Mõõtude (vt lk 16)



Varuosad (vt lk 17)



Kontrollsertifikaat (vt lk 20)

Paigaldamine vt lk 10

⚠ Drošības norādes

- ⚠ Montāžas laikā, lai izvairītos no saspiedumiem un iegriezumiem, nepieciešams nēsāt cimdus.

Norādījumi montāžai

- Pirms montāžas nepieciešams pārbaudīt, vai produktam transportēšanas laikā nav radušies bojājumi. Pēc iebūvēšanas bojājumi, kas radušies transportēšanas laikā, vai virsmas bojājumi netiek atzīti.
- Jāievēro attiecīgās valstīs spēkā esošās montāžas prasības.

Neizmantojiet silikonu, kas satur etiķskābi!



Izmērus (skat. lpp. 16)



Rezerves daļas (skat. lpp. 17)



Pārbaudes zīme (skat. lpp. 20)

Montāža skat. lpp. 10





Sigurnosne napomene

- △ Prilikom montaže se radi sprečavanja prignječenja i posekotina moraju nositi rukavice.

Instrukcije za montažu

- Pre montaže se mora proveriti da li je proizvod oštećen pri transportu. Nakon ugradnje se ne priznaju nikakve reklamacije koje se odnose na površinska i transportna oštećenja.
- Treba se pridržavati propisa koji u određenim zemljama važe za instalacije.



Nemojte koristiti silikon koji sadrži sircetnu kiselinu!

Mere (vidi stranu 16)



Rezervni delovi (vidi stranu 17)



Ispitni znak (vidi stranu 20)



Montaža vidi stranu 10



Sikkerheshenvisninger

- △ Bruk hansker under montasjen for å unngå klem- og kuttskader.

Montagehenvisninger

- Før montasjen skal produktet sjekkes for transportskader. Etter monteringen aksepteres ikke noen transport- eller overflateskader.
- Gjeldende retningslinjer for rørleggerarbeid i de enkelte land skal følges.



Ikke bruk silikon som inneholder eddiksyre!

Mål (se side 16)



Serviceleder (se side 17)



Prøveemerke (se side 20)



Montasje se side 10



Указания за безопасност

- △ При монтажа трябва да се носят ръкавици, за да се избегнат наранявания поради притискане или порязване.

Указания за монтаж

- Преди монтажа продуктът трябва да се провери за транспортни щети. След монтажа не се признават транспортни или повърхностни щети.
- Трябва да бъдат спазвани валидните в съответните страни предписания за инсталиране.



Не използвайте силикон, съдържащ оцетна киселина!

Размери (вижте стр. 16)



Сервизни части (вижте стр. 17)



Контролен знак (вижте стр. 20)



Монтаж вижте стр. 10



Udhëzime sigurie

- △ Për të evituar lëndimet e pickimeve ose të prerjeve gjatë procesit të montimit duhet që të vishni doreza.

Udhëzime për montimin

- Përpara montimit duhet që produkti të kontrollohet për dëmtime nga transporti. Pas instalimit nuk do të njihet asnjë dëmtim nga transporti ose dëmtim i sipërfaqes.
- Duhet të respektohen linjat udhëzuese të instalimit, të vlefshme për vendet respektive.



Mos përdorni silikon që në përbërje ka acid acetik.

Përmasat (shih faqen 16)



Pjesët e servisit (shih faqen 17)



Shenja e kontrollit (shih faqen 20)



Montimi shih faqen 10



⚠️ تنبيهات الأمان

⚠️ يجب إرتداء قفازات لليد أثناء التركيب لتجنب حدوث أخطار الإنحشار أو الجروح.

تعليمات التركيب

• قبل القيام بعملية التركيب، يجب فحص المنتج للتأكد من خلوّه من أية تلفيات ناتجة عن النقل. بعد القيام بعملية التركيب، لن يتم الاعتراف بوجود أية تلفيات سطحية أو تلفيات ناتجة عن عملية النقل.

• يجب مراعاة القواعد الخاصة بالتركيب وأعمال السباكة وفقاً للوائح الخاصة بكل بلد.

هام! لا تستخدم السليكون الذي يحتوي على أمضاض!



أبعاد (راجع صفحة 16)



قطع الغيار (راجع صفحة 17)



شهادة اختبار (راجع صفحة 20)



التركيب راجع صفحة 10



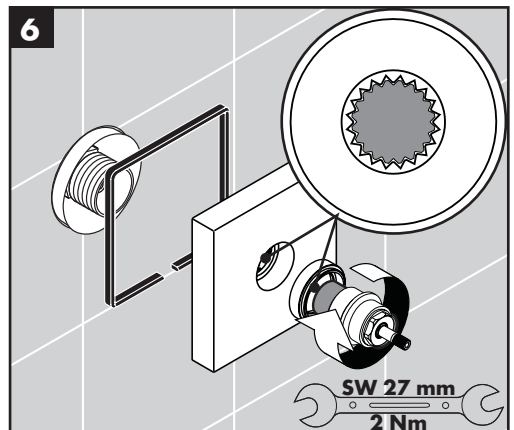
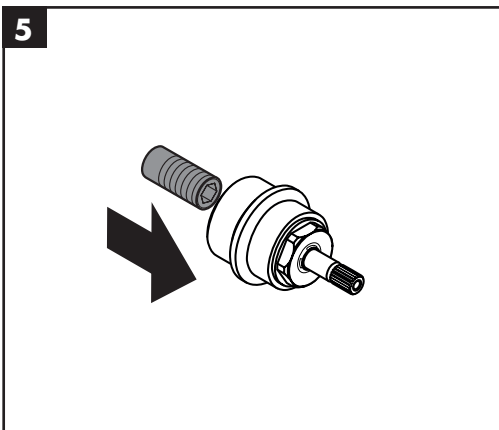
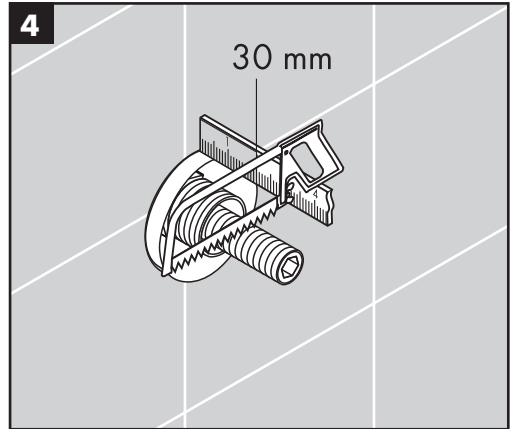
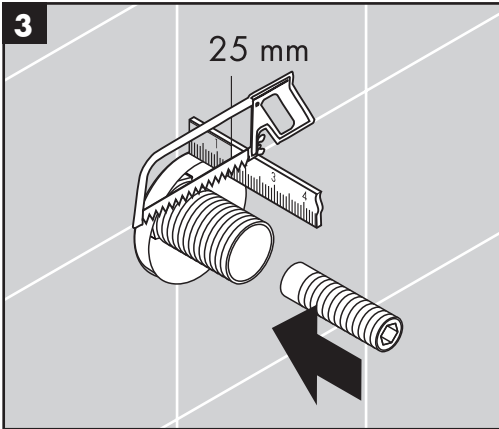
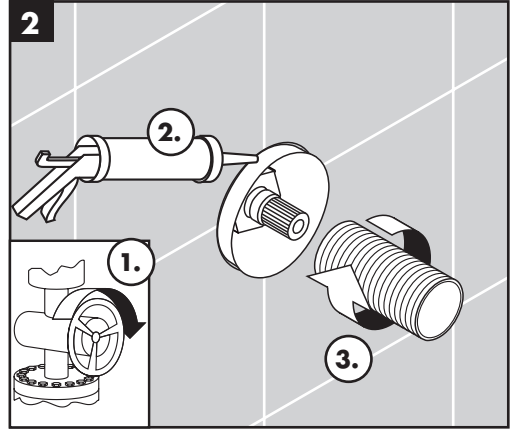
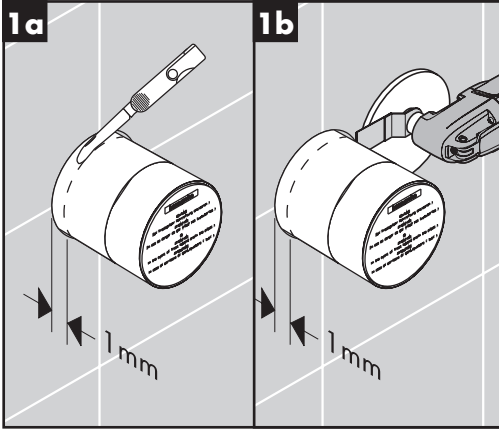

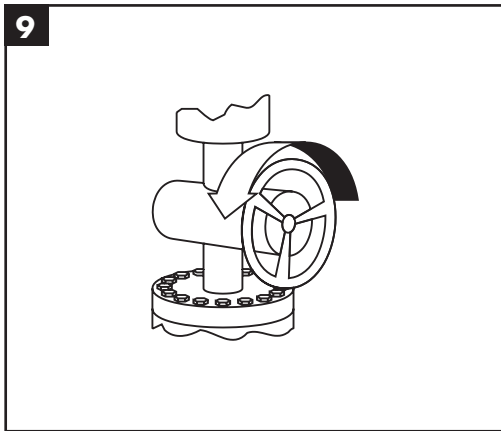
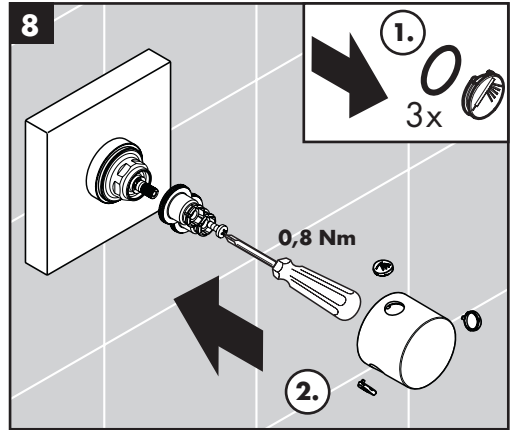
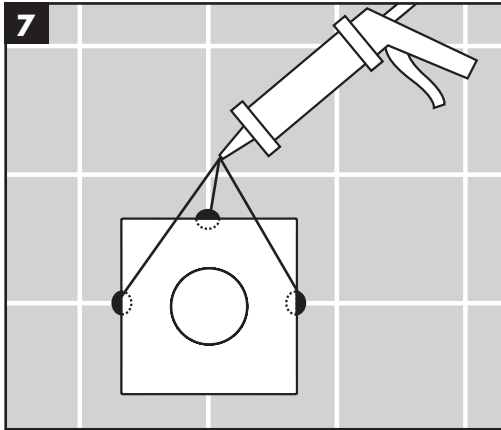

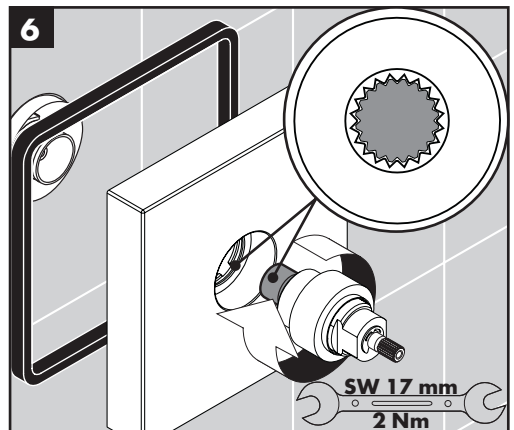
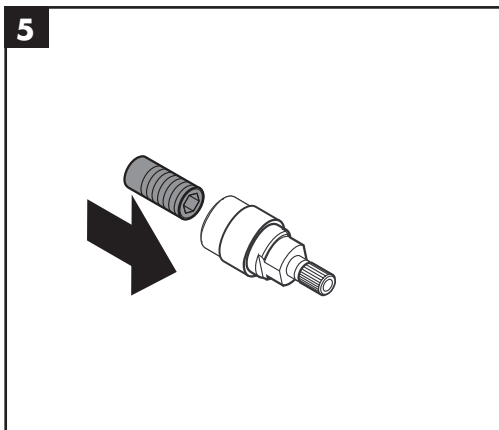
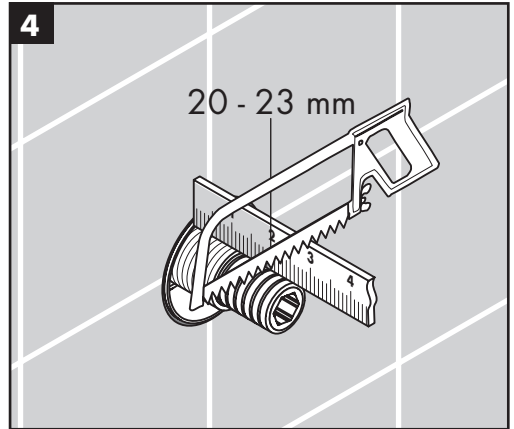
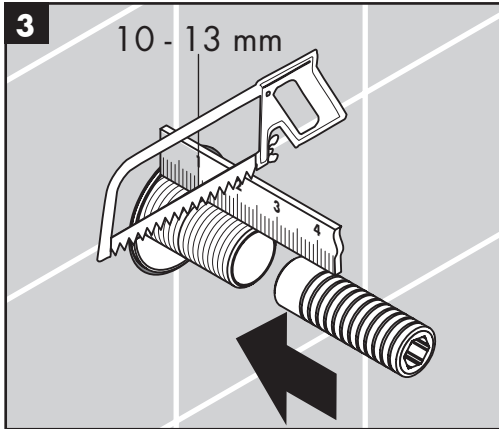
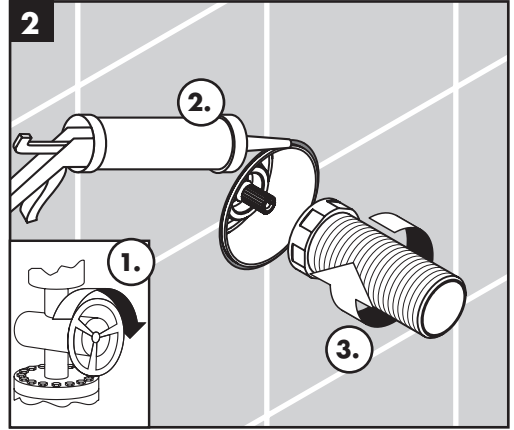
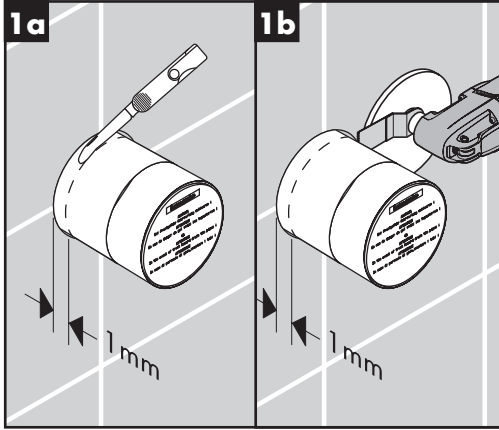

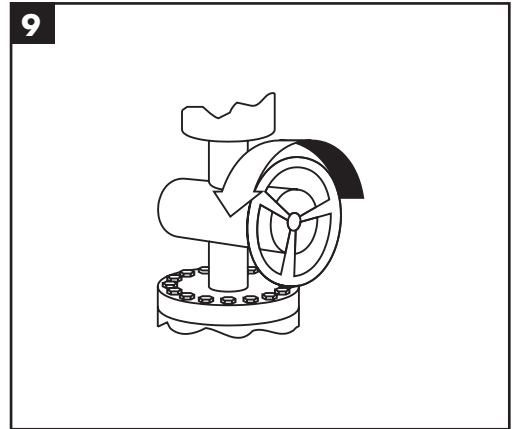
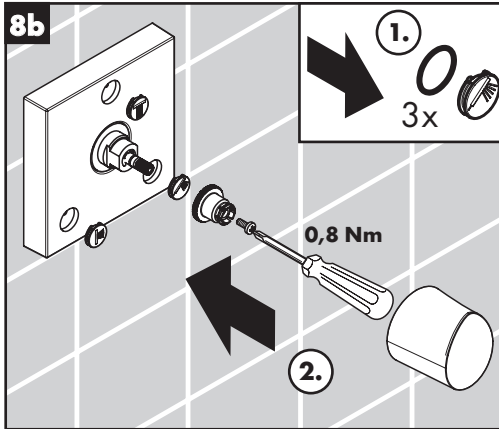
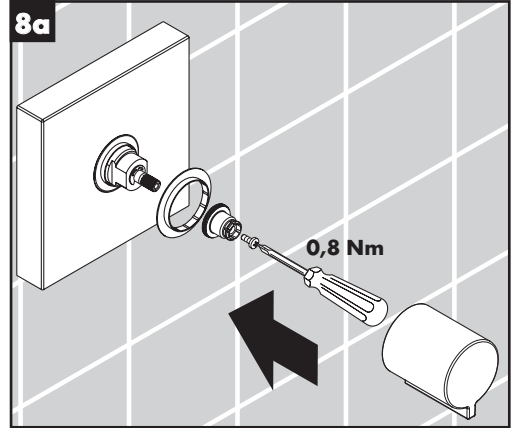
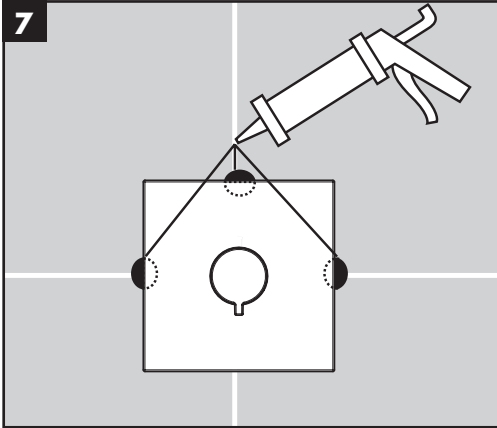

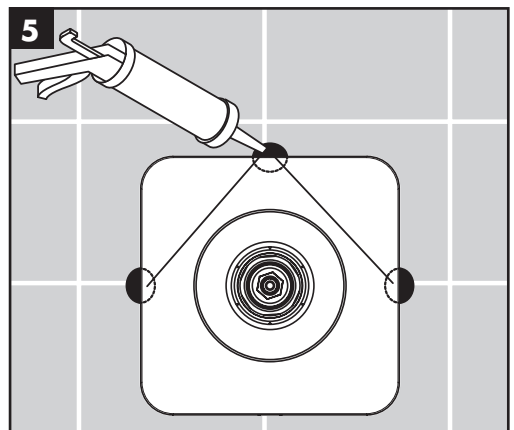
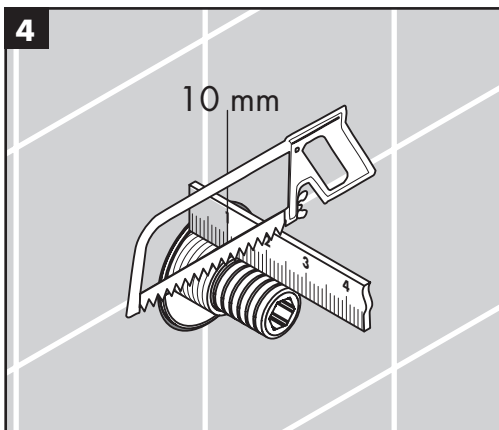
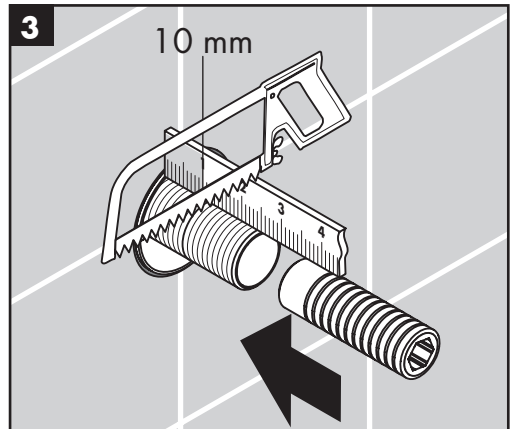
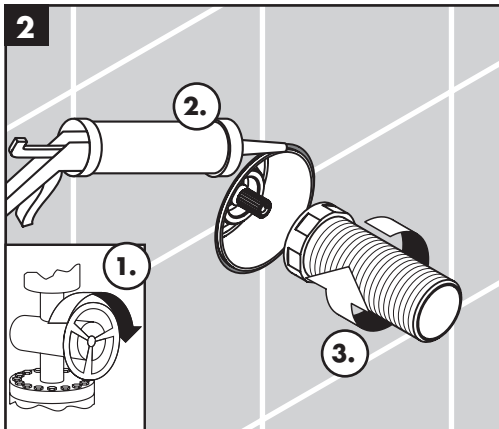
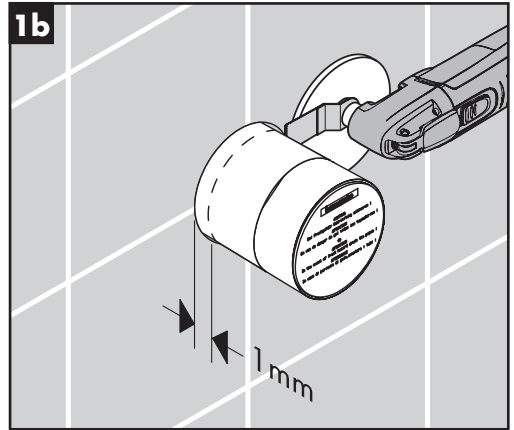
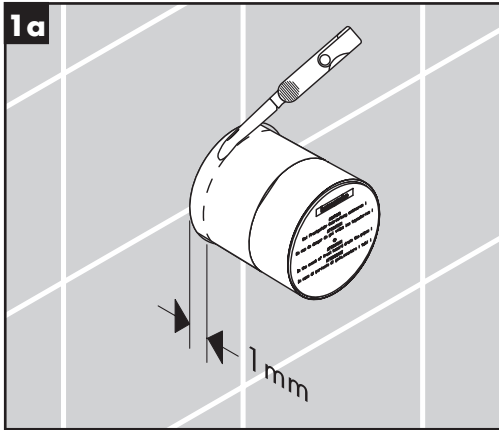

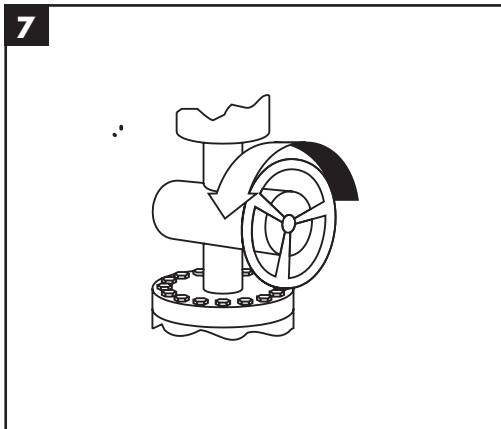
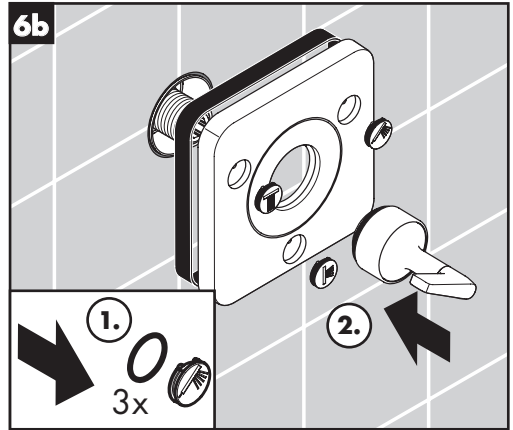
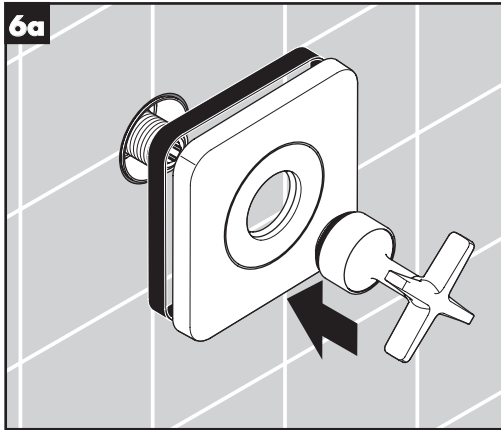



Starck 10932000

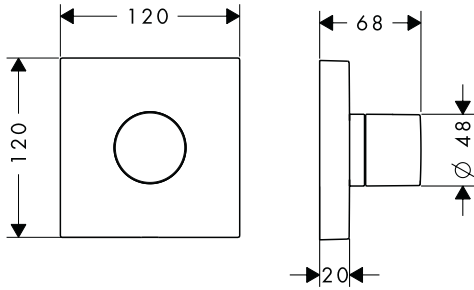

Starck 10972000 / 10972140

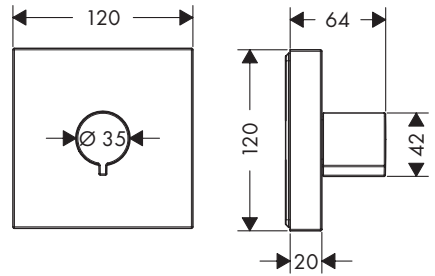

Starck Organic 12731000 / 12771000

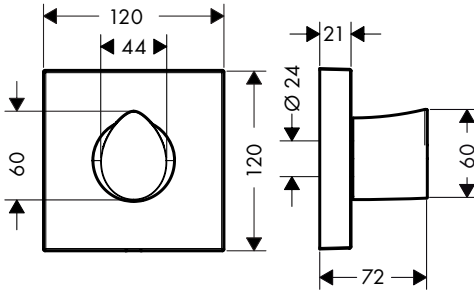

Citterio E 36771000

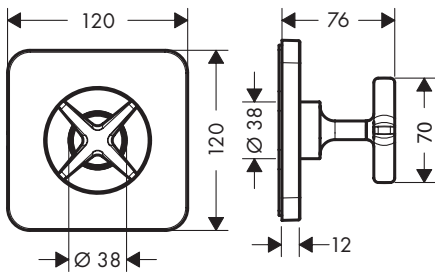

Citterio E 36772000

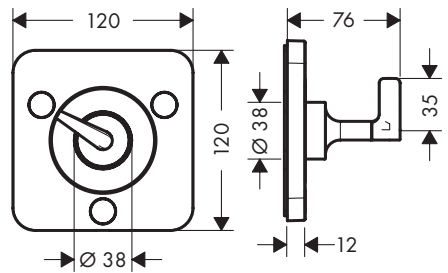



Starck
10932000

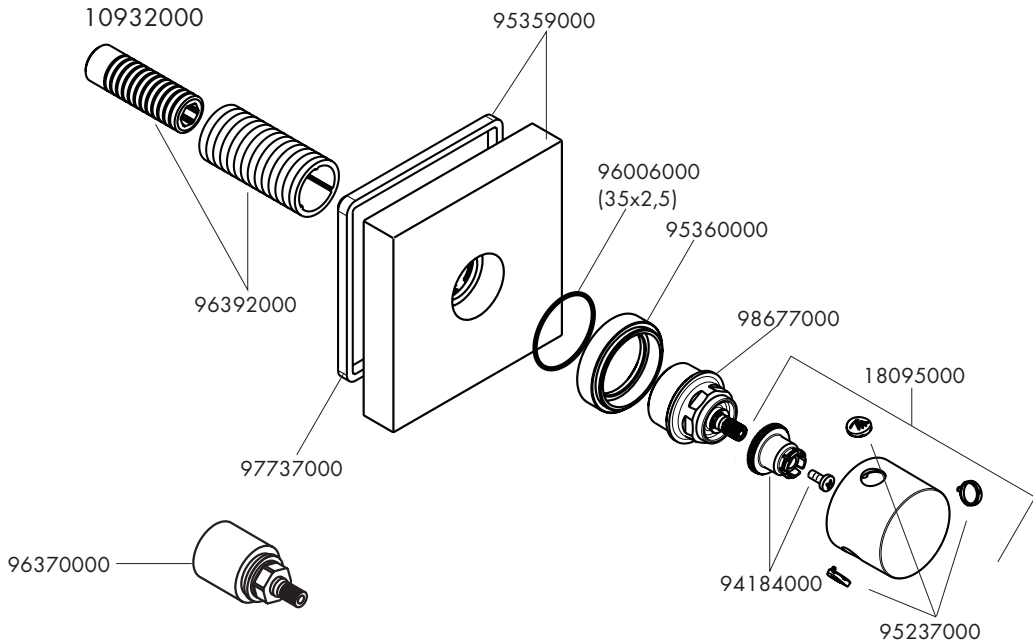

Starck
10972000 / 10972140

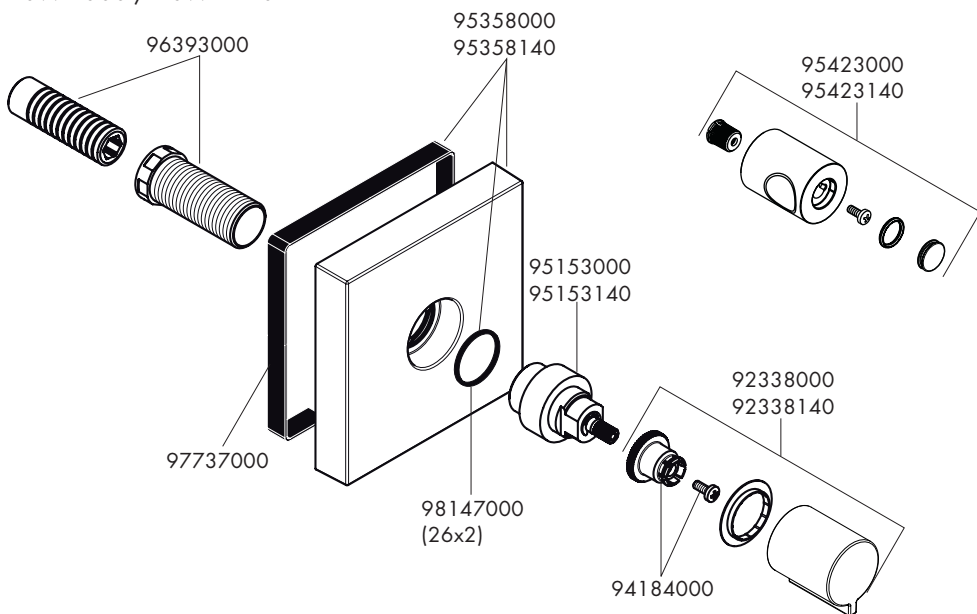



Starck Organic

12731000

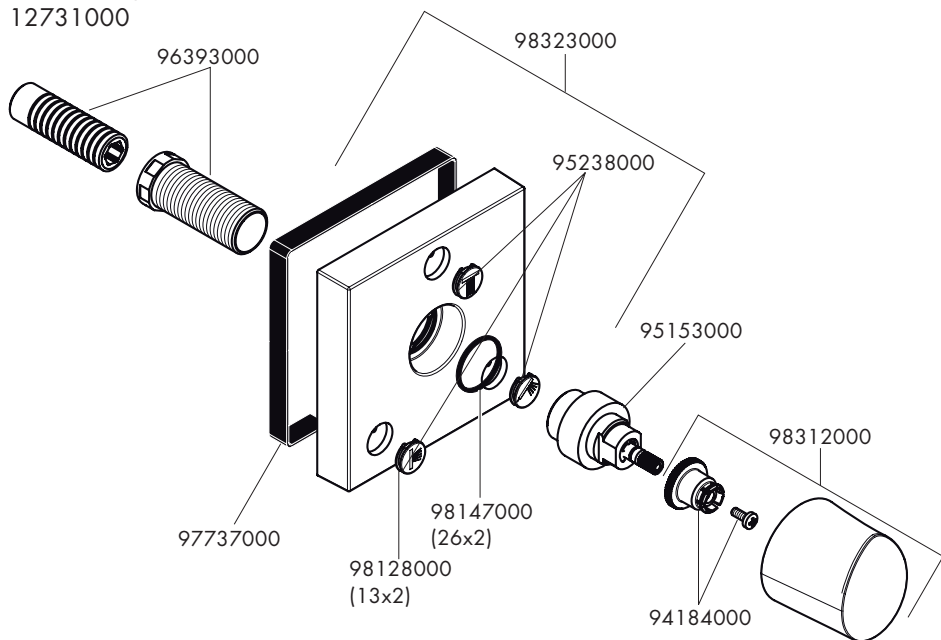

Starck Organic

12771000

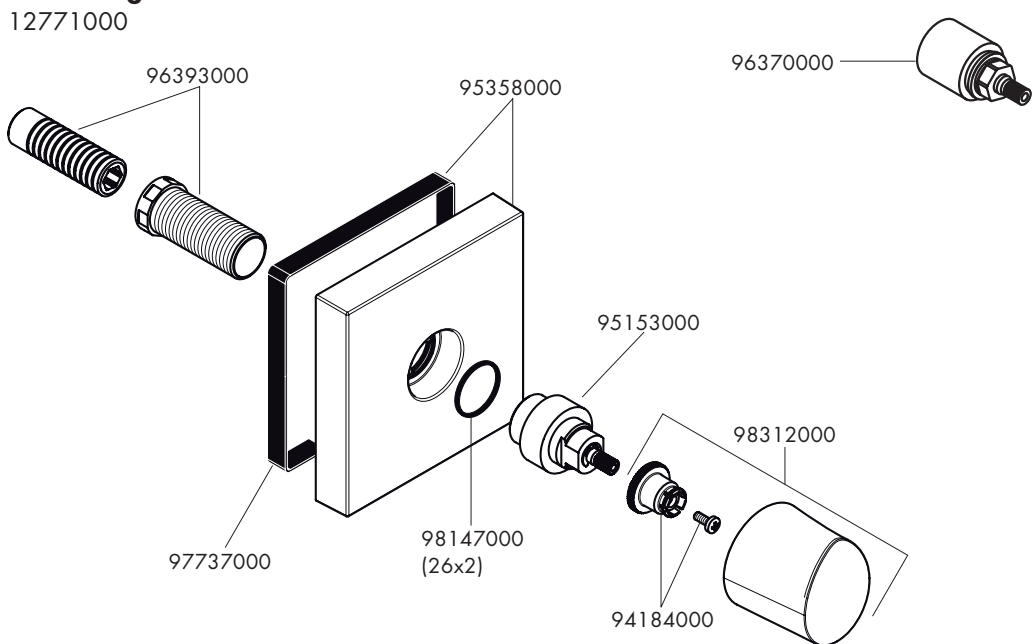



Citterio E
36772000

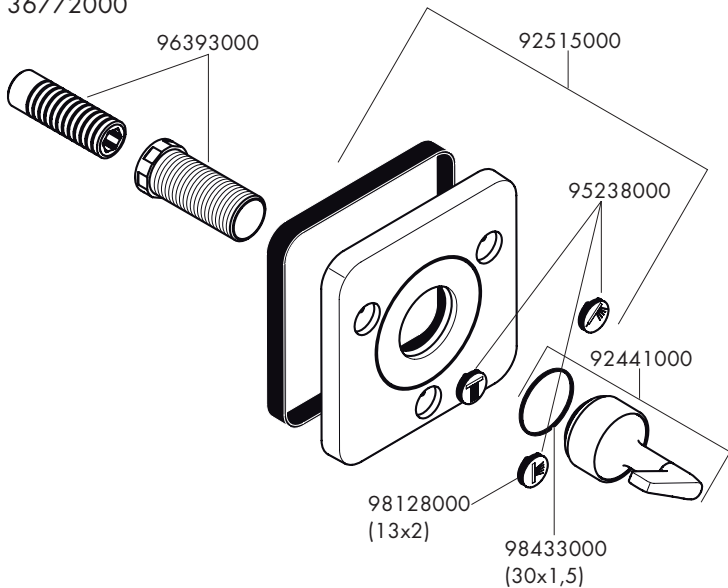

Citterio E
36771000

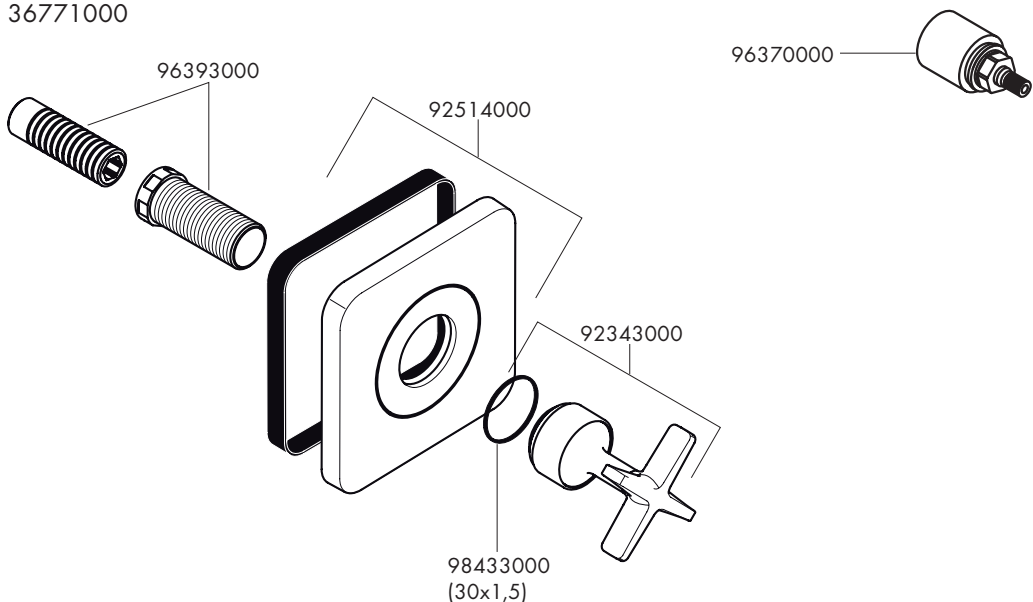



	P-IX	DVGW	MCA	SVGW	WRAS	KIWA	NF	ACS	ETA
10932000				X	X				
10972000 / 10972140				X	X				
12731000					X				
12771000					X				
36771000									
36772000									